

DETAILS

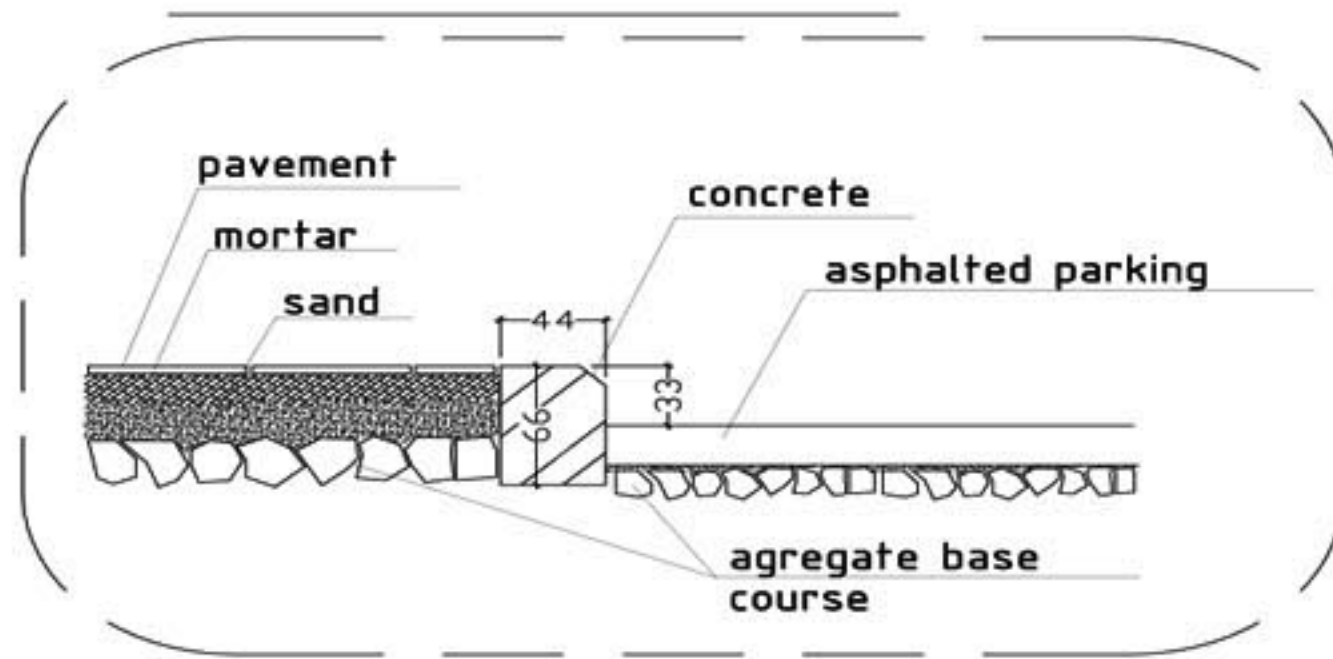

Detail separation side walk/parking

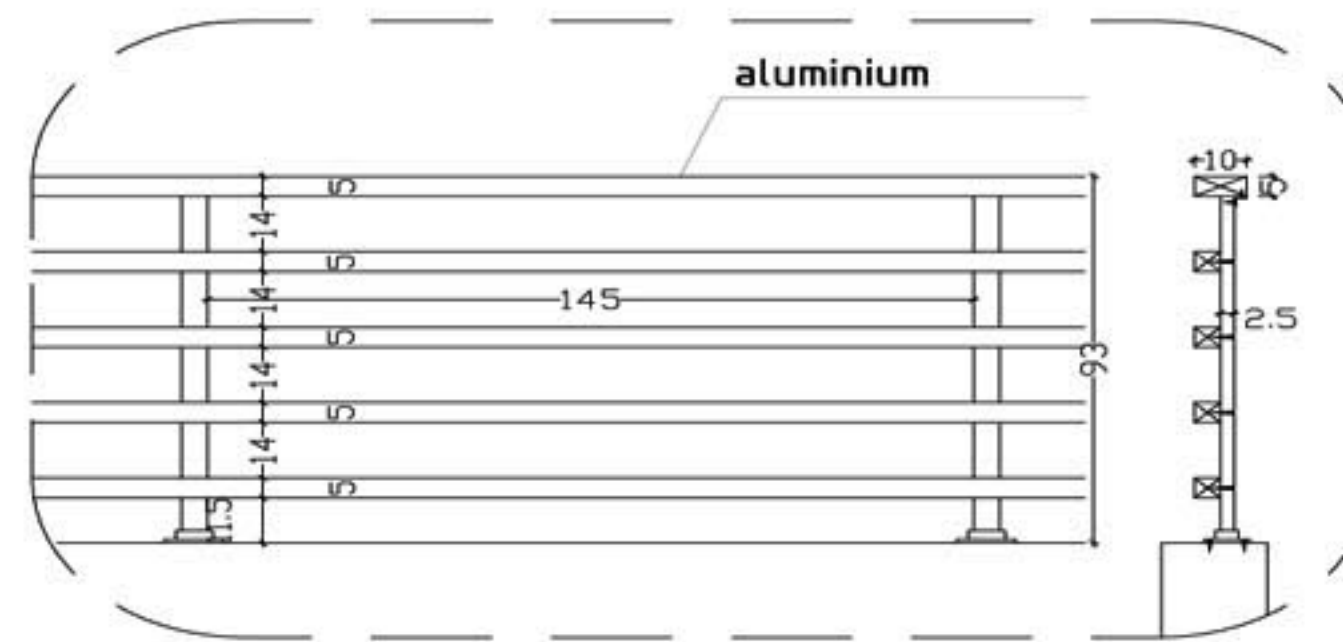

Detail balustrade type A (sc:1/25)

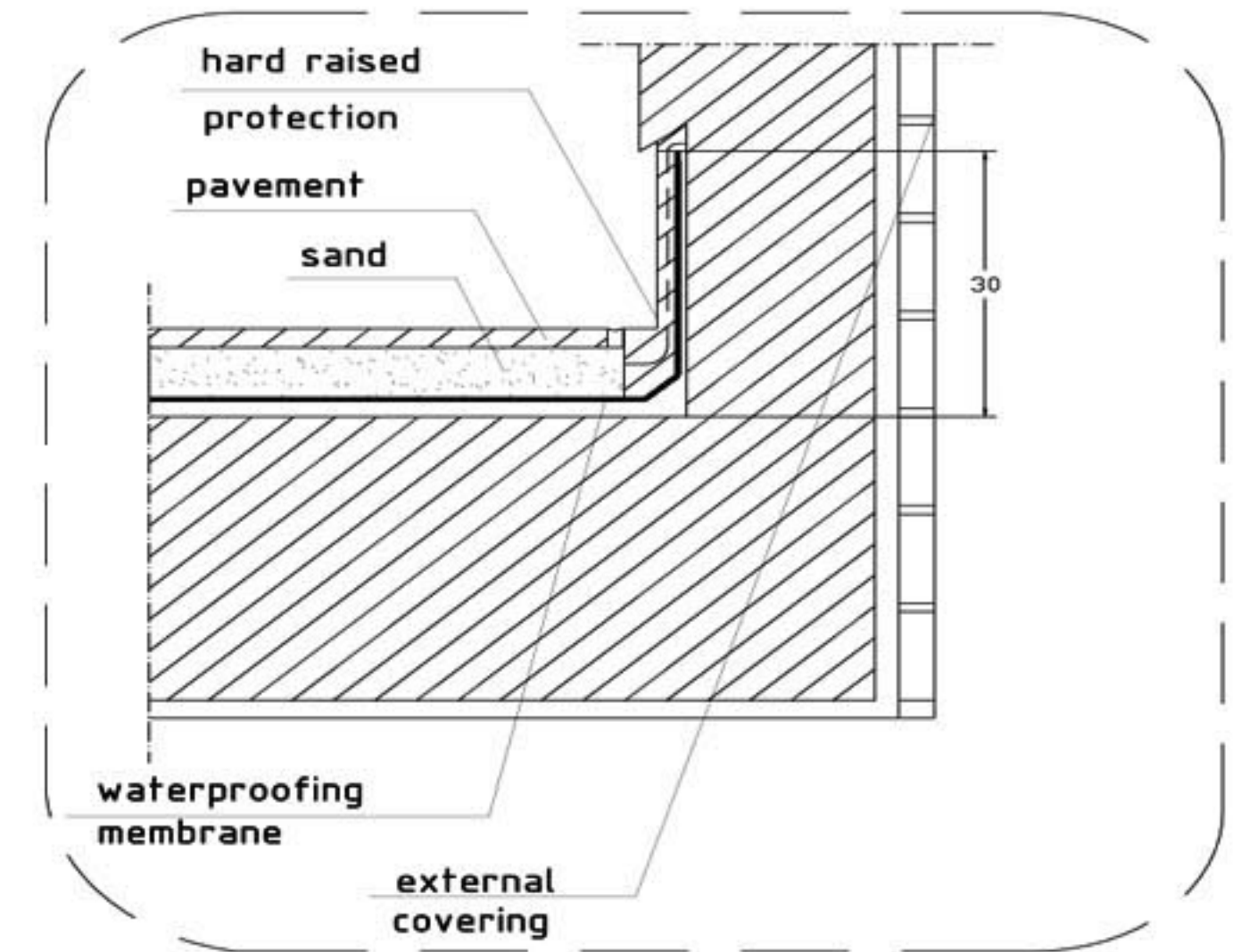

Detail waterproofing (sc:1/10)

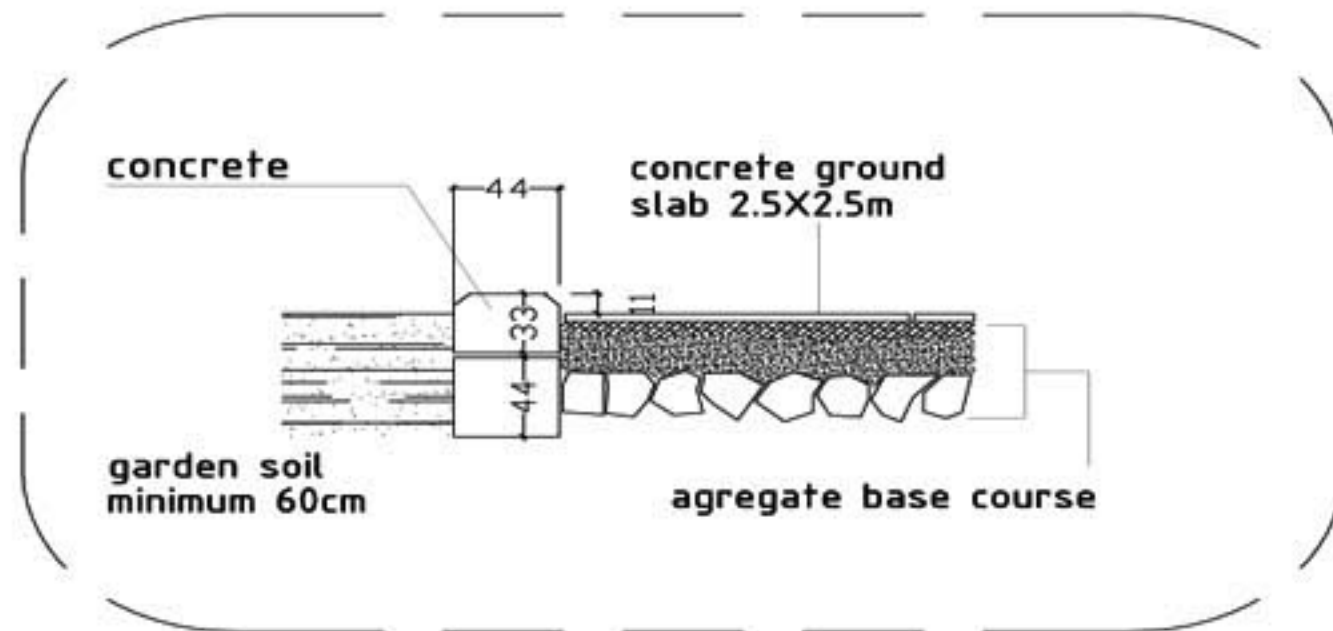

Detail separation garden/ play ground

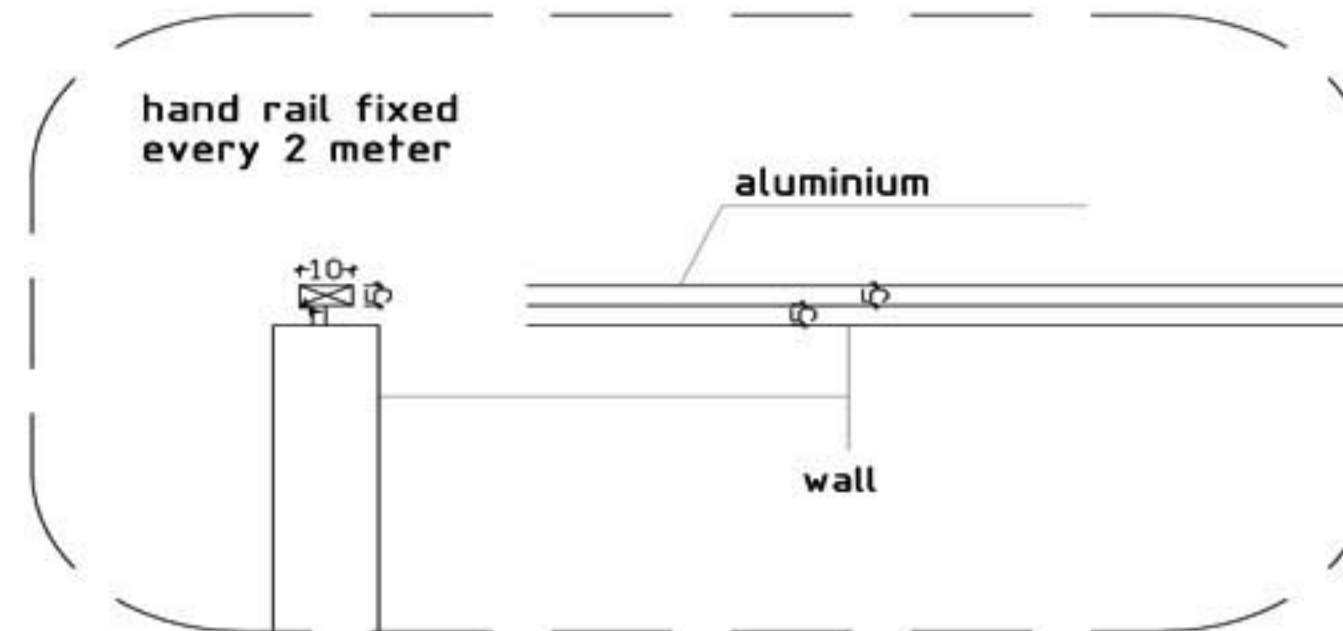

Detail balustrade type B (sc:1/25)

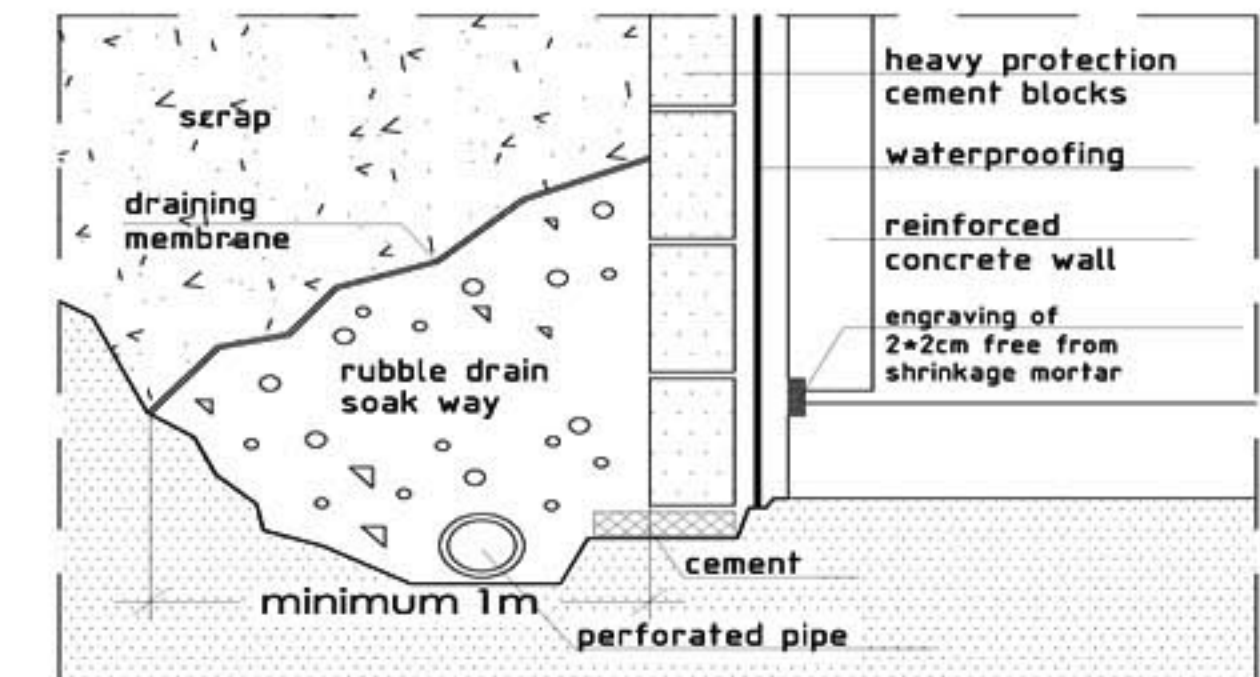

Detail waterproofing earth retaining wall

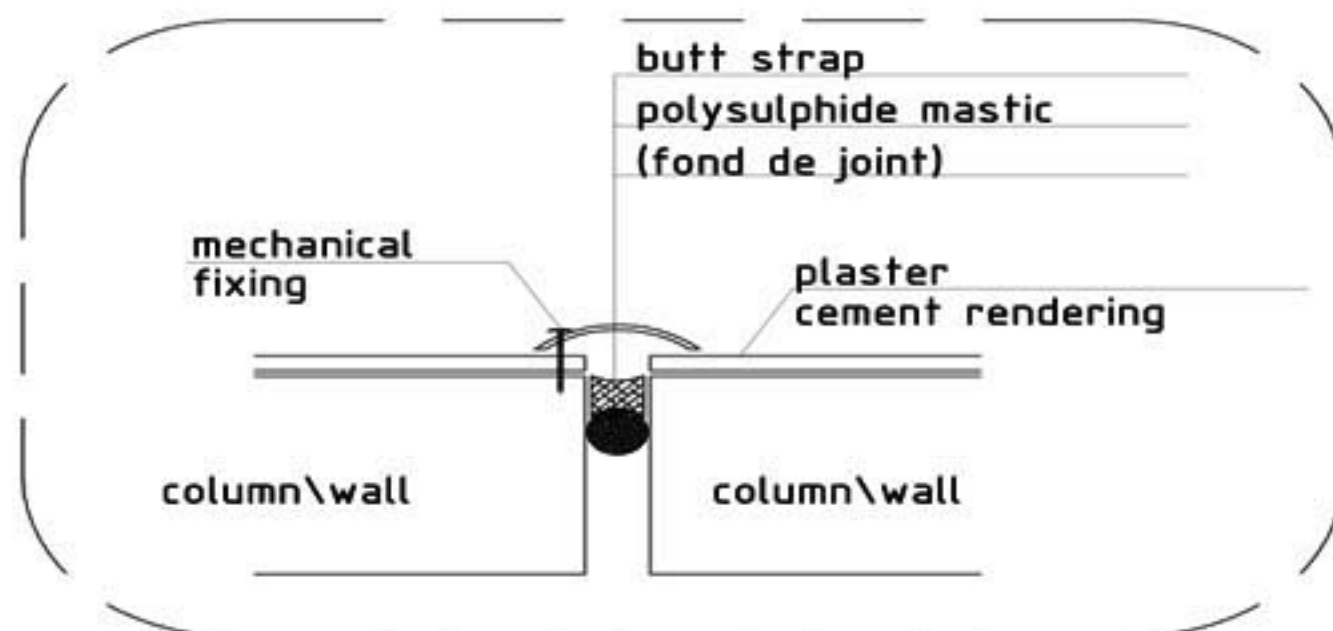

Detail expansion joint in elevation (no scale)

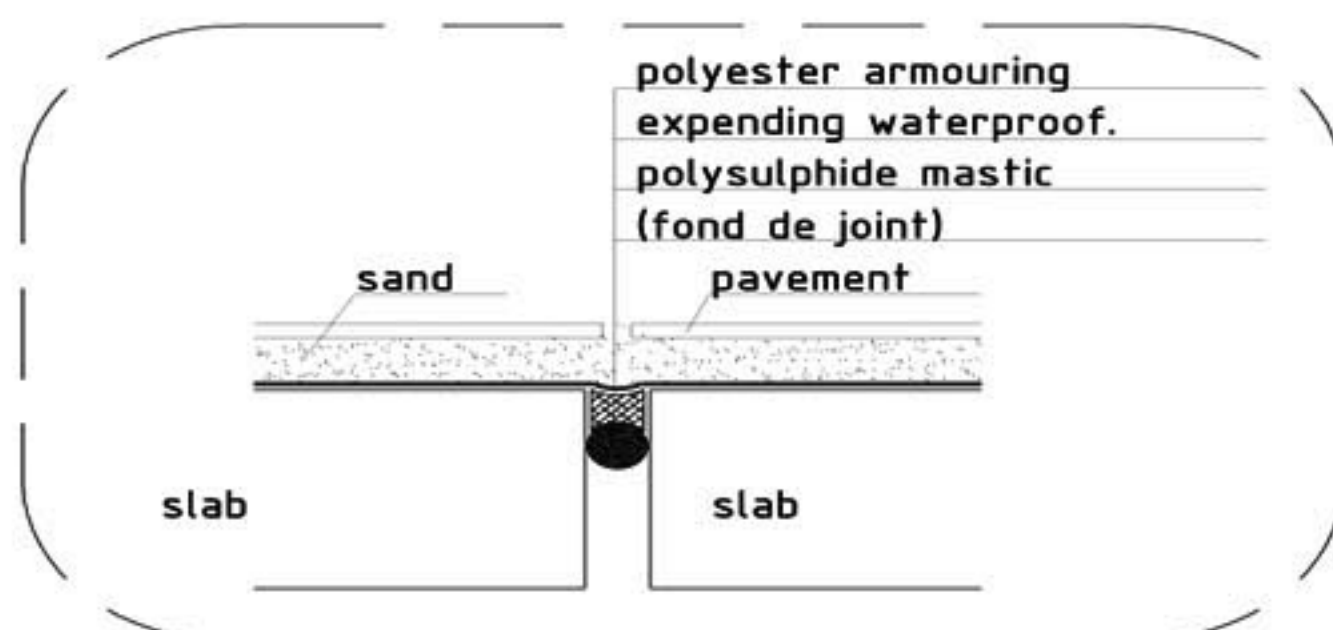

Detail expansion joint in terrace (no scale)

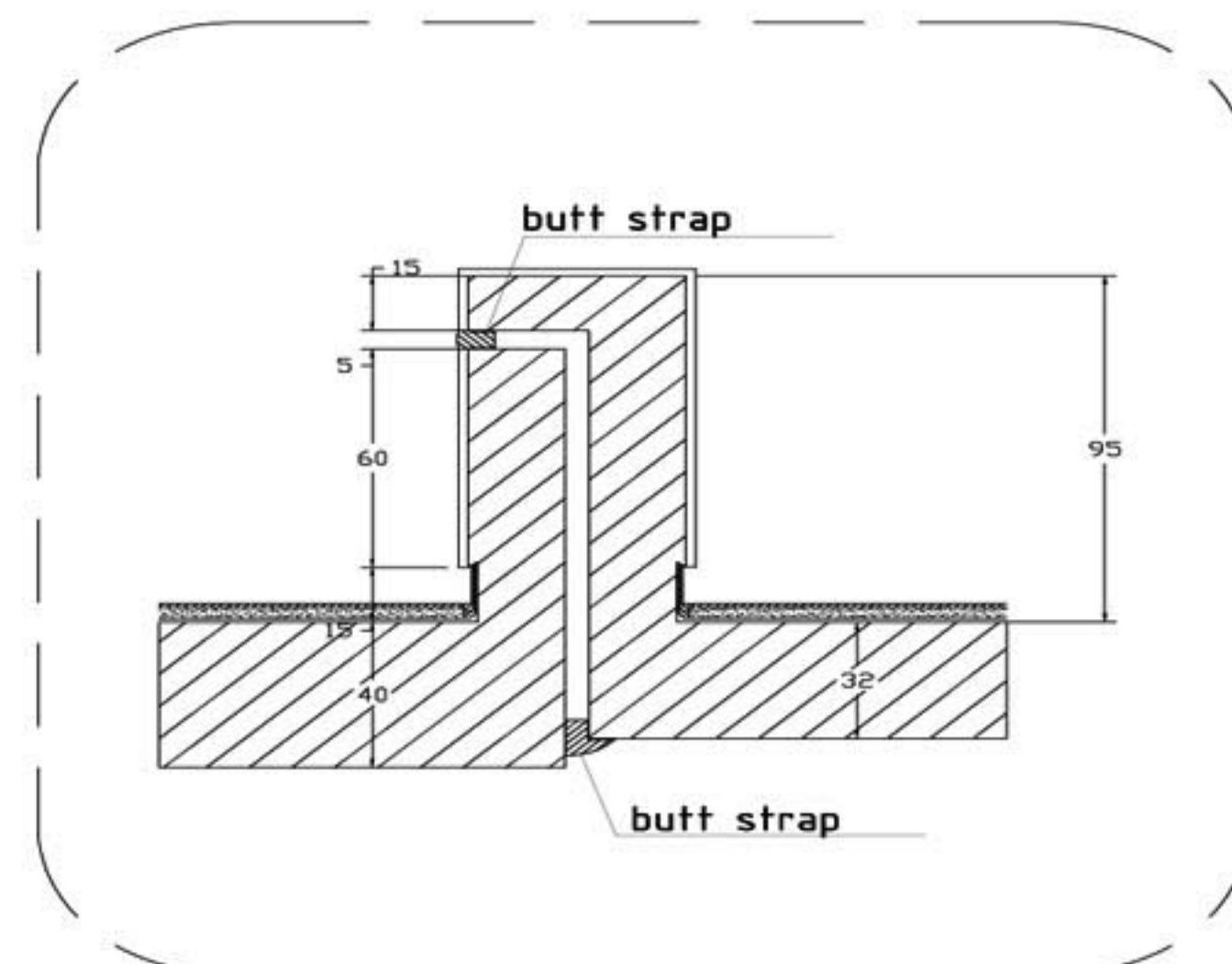

Detail expansion joint (sc:1/25)

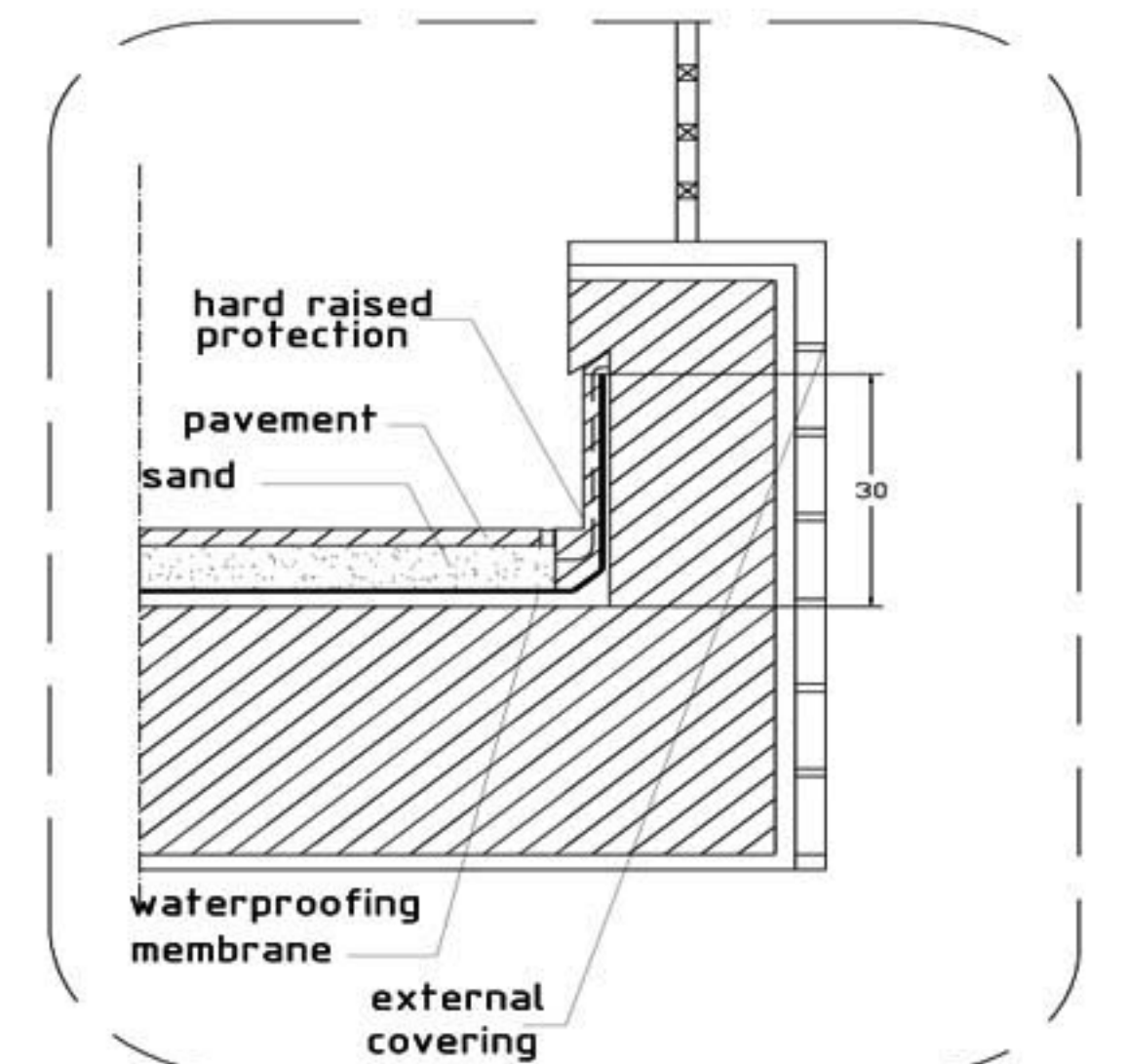

Detail waterproofing (sc:1/10)